



MGO COOLING SYSTEM

MAYEKAWA MFG. CO., LTD.
Marine Division
Ecology and Energy Dept.

Current regulation : New sulphur limits in marine fuel

1. Sulphur control for international shipping

1.1 Revised IMO MARPOL Annex VI – 2008

- SO_x, PM, Fuel – Regulations
- Regulation 14
- Sulphur Oxides (SO_x) and Particulate Matter (PM)

The sulphur content of any fuel oil used globally shall not exceed:

- 4.5% m/m S, prior to 1 January 2012
- 3.5% m/m S, on and after 1 January 2012
- 0.5% m/m S, on and after 1 January 2020

The sulphur content of any fuel oil used in designated emission control areas (ECA) shall not exceed:

- 1.5% m/m S, prior to 1 July 2010
- 1.0 %m/m S, on and after 1 July 2010
- 0.1% m/m S, on and after 1 January 2015

Current regulation : New sulphur limits in marine fuel

1.3 European Union

- Council Directive 1999/32/EC of 26 April 1999 relating to a reduction in the sulphur content of certain liquid fuels and amending Directive 93/12/EEC, amended by Directive 2005/33/EC.
- As of 1 January 2010, ships berthed for longer than two hours at ports in the European Union are required to switch to 0.1%- sulphur-content marine fuel oil according to Article 4b of Directive 2005/33/EC.

2. Operational conditions/requirements approaching ports in Europe related to fuel change over.

- Destination : Port inside an ECA
 - Global cap 4.5 (3.5)% S, Heavy Fuel Oil, heated
 - ECA 1.5 (1)% S, Heavy Fuel or Distillate Oil, heated or unheated
 - At Berth 0.1% S, Low Sulphur Distillate Oil, unheated or cooled
- Destination: Port without ECA
 - Global cap 4.5 (3.5)% S, Heavy Fuel Oil, heated
 - At Berth 0.1% S, Low Sulphur Distillate Oil, unheated or cooled

Surfaced problem

Ship's machineries are not designed to use with low sulphur fuel of which the viscosity is very low, so their performance or lubrication, etc. are affected and deteriorated.



Solution

By cooling the fuel, it is possible to increase the viscosity.

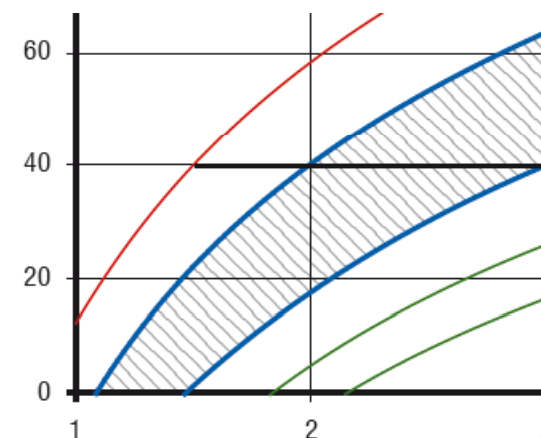
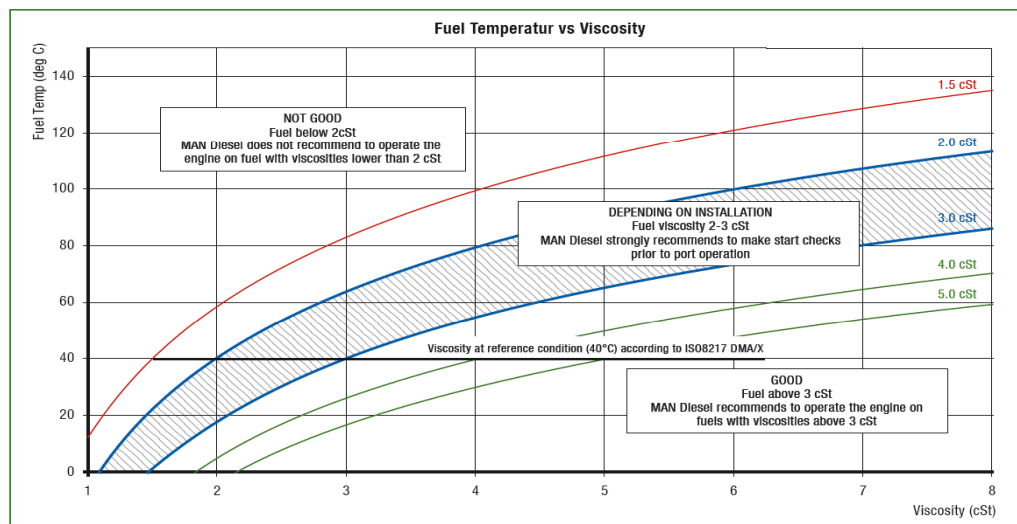

How to read the chart ?

- According to ISO8217 DMA/X, the nominal viscosity (cSt) is at reference condition of 40C.

For example ;

- In order to obtain 3 cSt of MGO with a viscosity 2 cSt at 40C, it is necessary to cool it down to 18C.

Location of MGO cooling system

Our standard MGO cooling system needs to be installed before the circulating pumps.

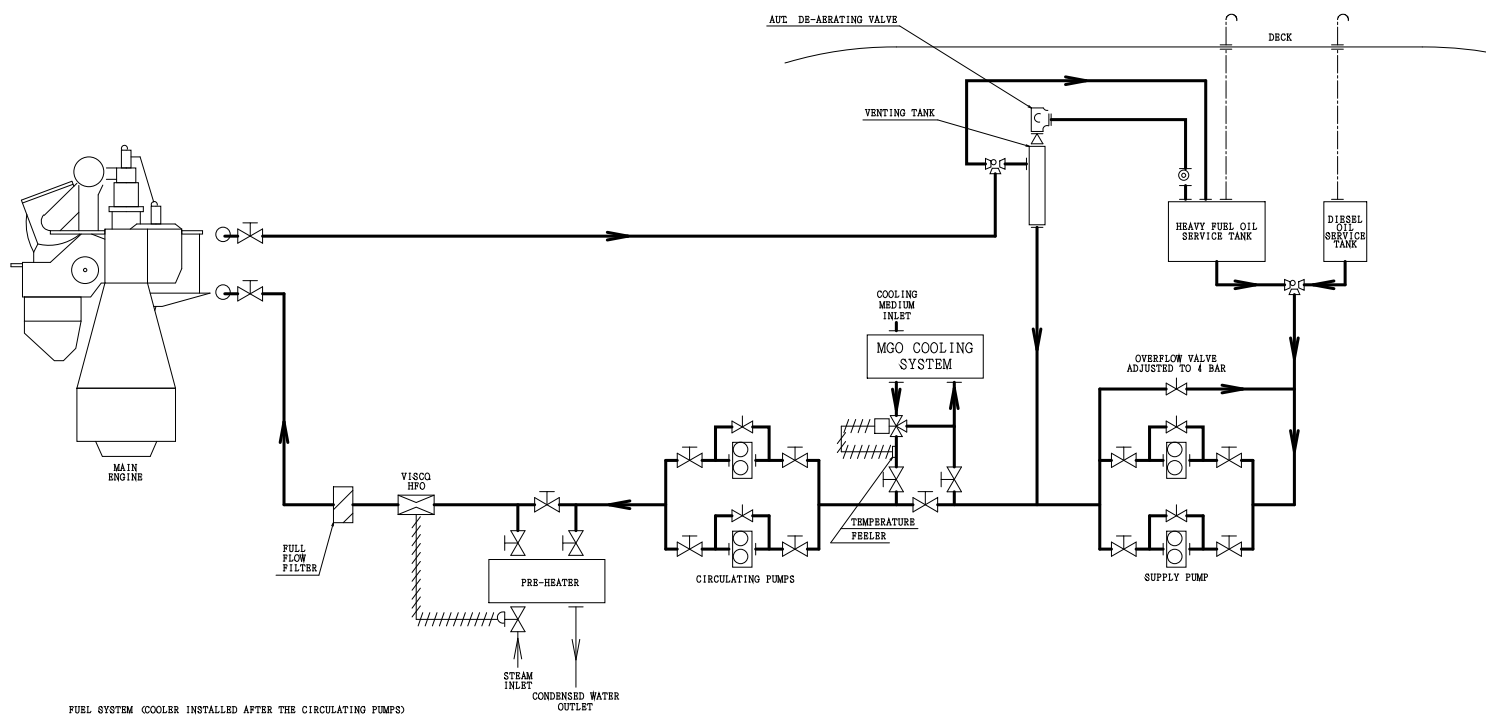

Mayekawa MGO cooling system

Indirect cooling system between fresh water and marine fuel (MGO)

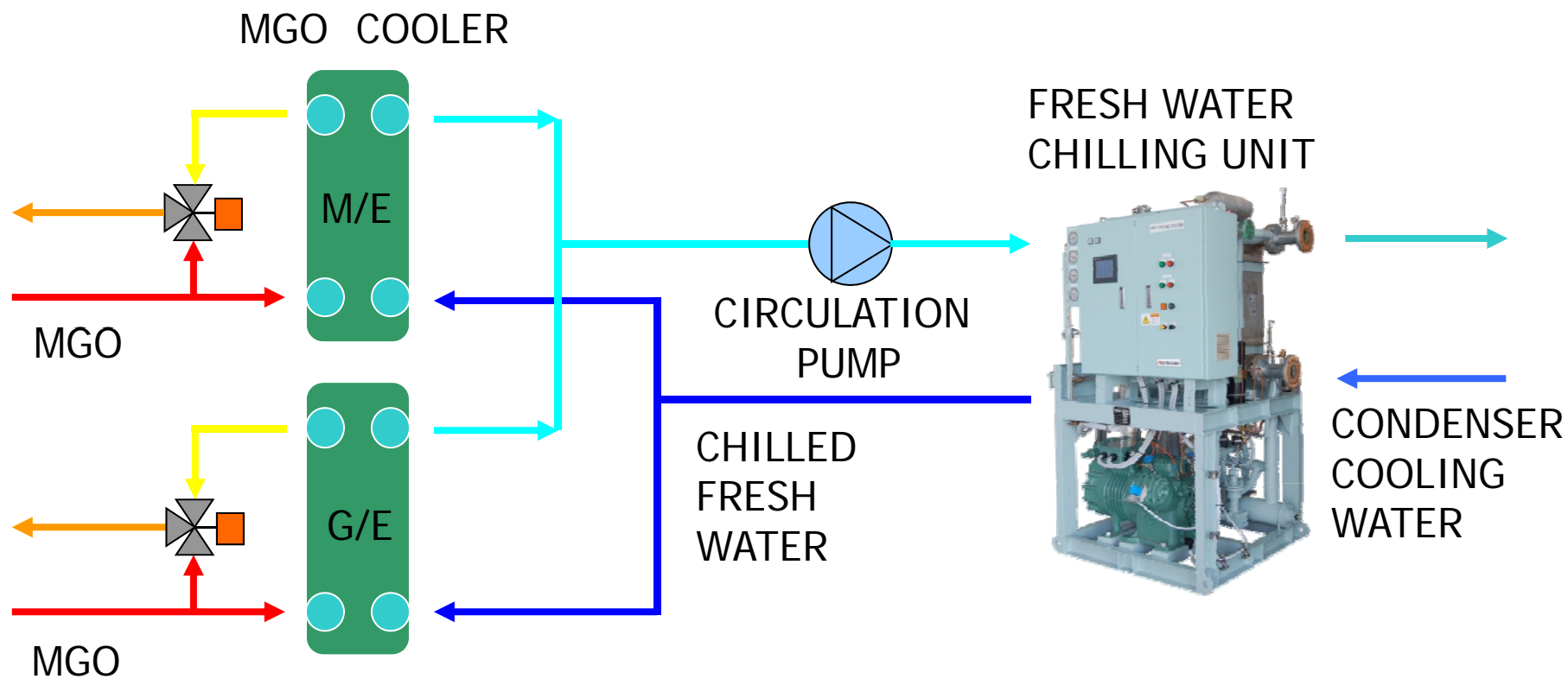

Mayekawa MGO cooling system

- The system consists of fresh water chilling unit, fresh water circulation pump, fresh water head tank and MGO coolers.
- And MGO to be cooled to the specific temperature being heat-exchanged by chilled fresh water.

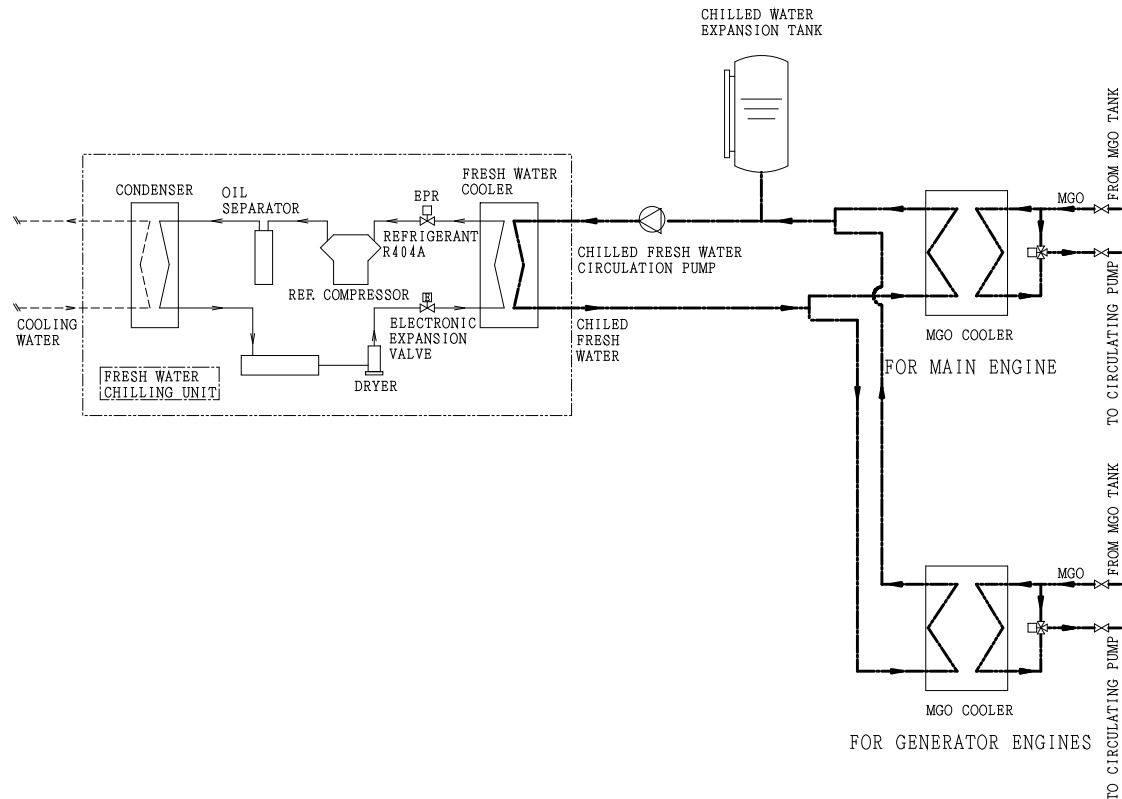

Advantages of MAYAKAWA's MGO cooling system

1. Compact and flexible designed fresh water chilling unit

- In the aim of installing the unit not only for the new building ships but also for the existing ships, our units are so designed as to minimize the foot print to be installed at the limited machinery space.
- For the condenser, it is possible to choose either fresh water cool or sea water cool type.

MGO fresh water chilling unit

① Fresh water condenser type (MMCS35F)

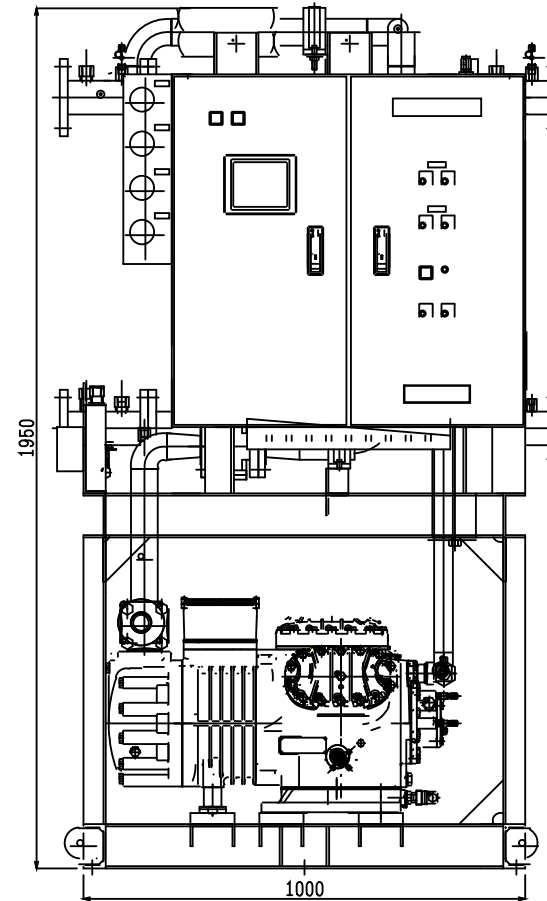
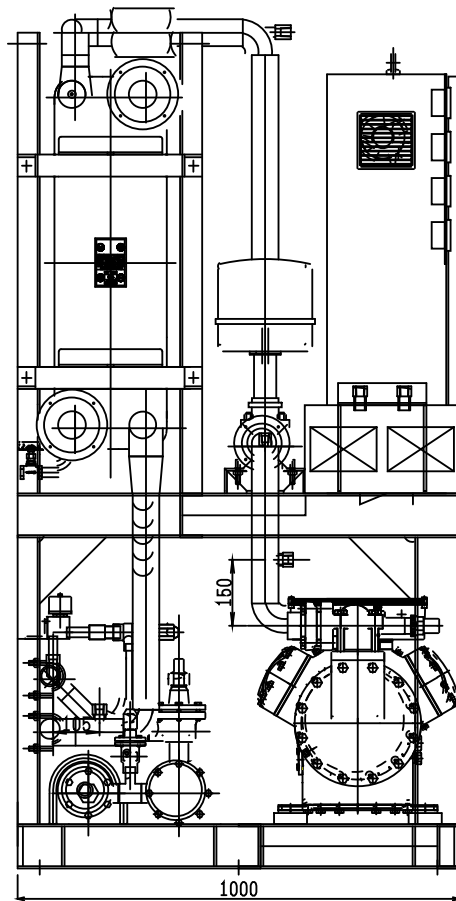

MGO fresh water chilling unit

② Sea water condenser type (MMCS35S)

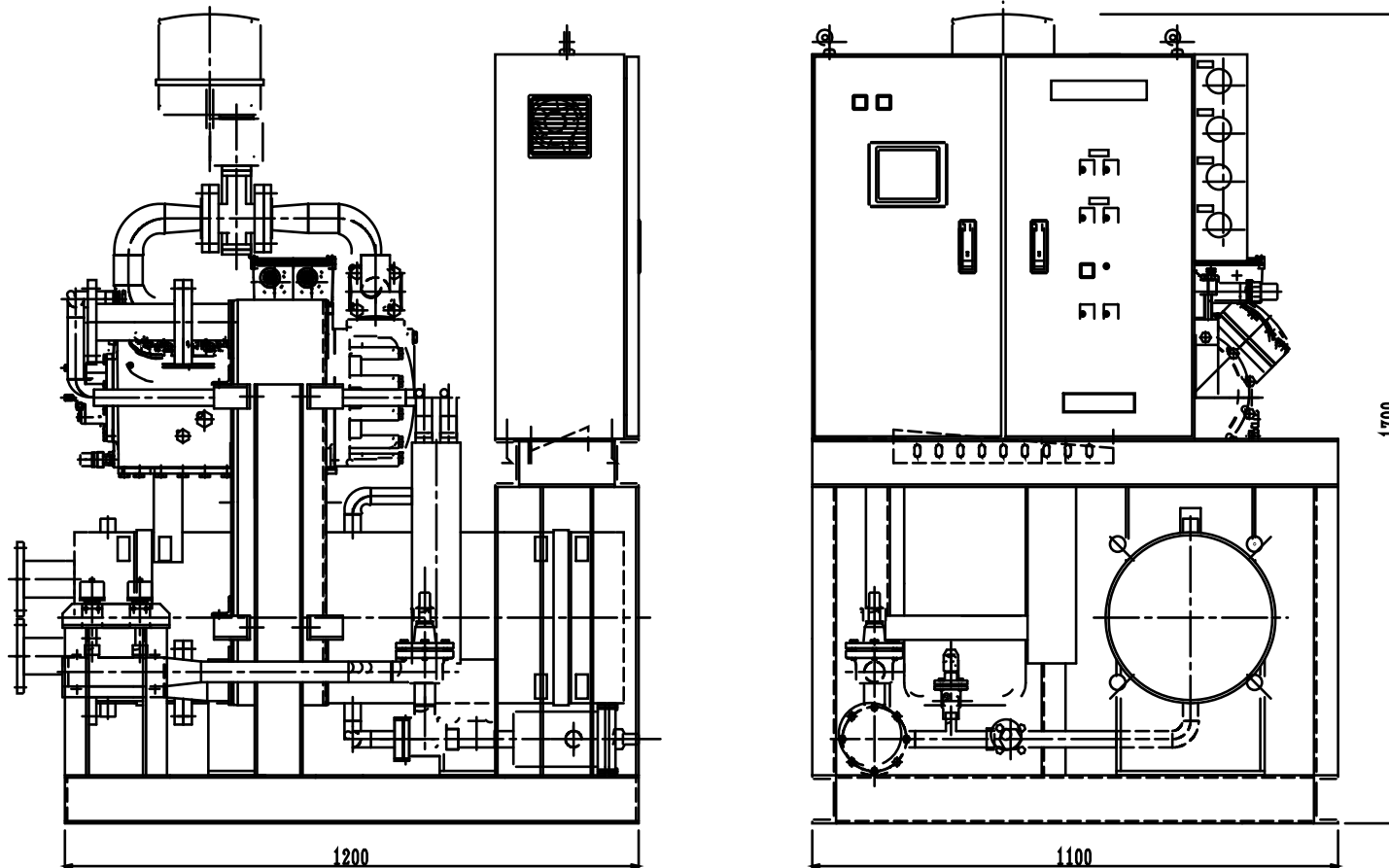

MGO fresh water chilling unit

③ Dimension of standard units (Fresh water condenser)

Model	El. Motor	Dimension of unit
MMCF20F	22 HP	1000L x 1000W x 1950H
MMCF25F	25 HP	1000L x 1000W x 1950H
MMCF30F	30 HP	1000L x 1000W x 1950H
MMCF35F	35 HP	1000L x 1000W x 1950H
MMCF40F	40 HP	1000L x 1000W x 1950H

MGO fresh water chilling unit

④ Selection and designing of Fresh water chilling unit

Optimum model of the unit can be selected based on the following conditions.

- Flow rate of the fuel supply pumps and circulating pumps.
- MGO temperature in the service tank.
- MGO temperature to be cooled before entering the circulating pumps or the engine.
- MGO temperature returned from the engine.

Advantages of MAYAKAWA's MGO cooling system

2. Very easy and reliable operation

- Utilizing Mayekawa electronic expansion valve system for the fresh water chiller, the outlet fresh water temperature is very precisely controlled and at the same time, superheating is controlled fully automatically, thus a very secured and reliable operation to be accomplished.
- The compressor's capacity control to be carried out step-wise according to the suction pressure and full automatic controlled EPR is installed on the suction line to maintain the system running at very low heat load. And with a combination of automatic controlled three way control valve installed on the outlet of MGO cooler, the MGO temperature to be finally controlled fully automatically and very accurately.
- To avoid heat contraction to main engine, generator engines and MGO piping, the cooling speed of MGO can be freely adjusted and controlled fully automatically.

Cooling curve at shop test

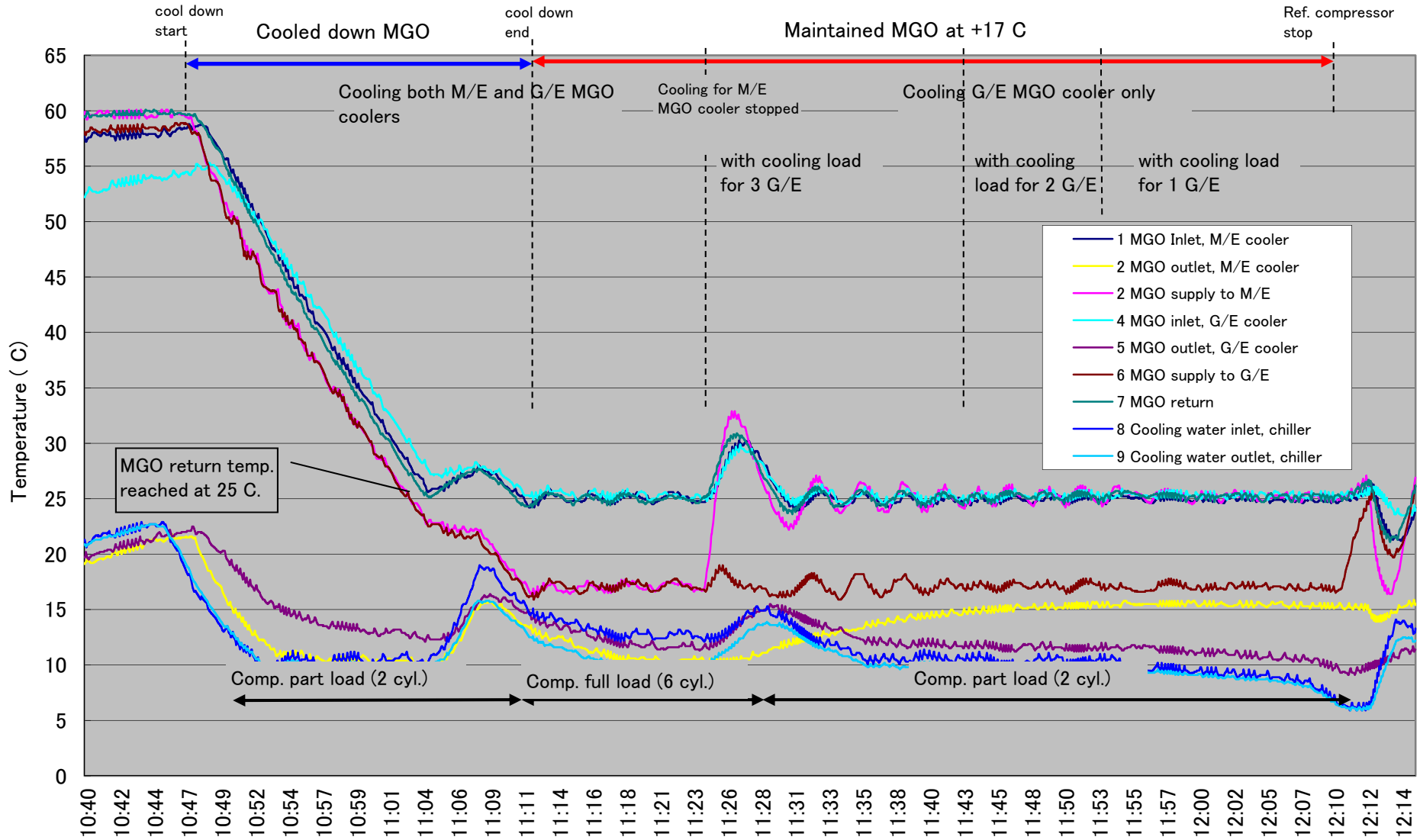

Advantages of MAYAKAWA's MGO cooling system

3. Mayekawa's worldwide service network

- Using our 27 worldwide locations of our branch offices, we can arrange a customer oriented service for the vessels sailing around the world.

Our contact details

MAYEKAWA MFG. CO., LTD.

Marine Division
Ecology and Energy Dept.

Address : 3-14-15, Koto-Ku, Botan, Tokyo, Japan

Telephone : +81-33642-9211

Facsimile : +81-33642-2815

Email : marine@mayekawa.co.jp

Web : <http://www.mayekawa.com>
<http://www.mayekawa.co.jp>